

SHIELDING DEVICES & EYE APPLICATORS

TUNGSTEN EYE SHIELDS For Electron or Superficial Shielding



Specifications

Tungsten Density: 17 g/cm³
Aluminum Density: 2.718 g/cm³

The user will have to determine an acceptable amount of backscatter to decide whether to use 0.5 mm or 1 mm aluminum cap. See diagram and table below.

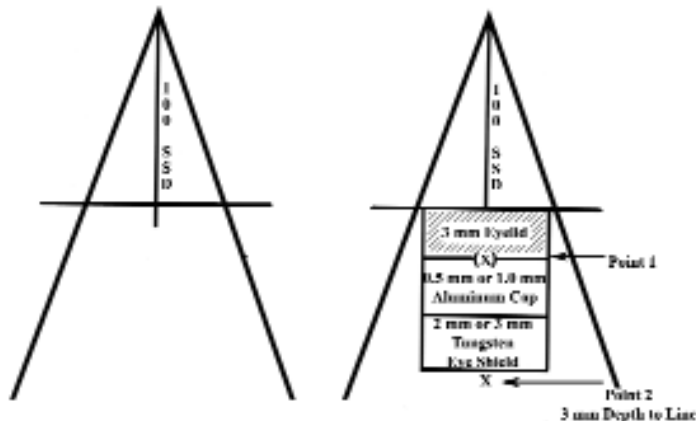

The doses are normalized to d_{max} without the eye shield (Diagram 1) using a 10 x 10 cone. When 1.00 Gy is delivered to d_{max} using 6 MeV with the shield, you get 1.08 Gy to the undersurface of the eyelid (Point 1) and 3.4% transmission to the lens (Point 2) (See table).

- Tungsten eye shields have less transmission than other eye shields

The Tungsten Eye Shield can use either the 0.5 mm or 1 mm thick anodized aluminum cap (both are included with each tungsten eye shield) to reduce the electron backscatter to the eyelid. The eye shield can be used without the aluminum cap when placed superficially.

Recommendations Based on Transmission Values:

The 2 mm tungsten eye shield should be used for 6 MeV, and the 3 mm tungsten eye shield should be used for 9 MeV. **These tungsten eye shields are not recommended for use above 9 MeV.**

TRANSMISSION USING XV-2 FILM*		DOSE IN Gy When 1.00 Gy is Delivered to d_{max} AT 3mm DEPTH*** USING TLD'S**		
6 MeV	9 MeV	6 MeV	9 MeV	
		0.72	0.77	Surface, No shield
		0.79	0.81	No Shield, Dose at Interface
3.4%	5.6%	1.08	1.11	2 mm Tungsten
3.0%	4.8%	1.03	1.06	2 mm Tungsten + 0.5 mm Aluminum
3.0%	4.4%	0.95	1.02	2 mm Tungsten + 1 mm Aluminum
2.5%	3.3%	1.12	1.13	3 mm Tungsten
2.4%	2.9%	1.02	1.05	3 mm Tungsten + 0.5 mm Aluminum
2.5%	2.8%	0.97	1.06	3 mm Tungsten + 1 mm Aluminum

Unreferenced data on this product is preliminary findings of Radiation Products Design, Inc. and is **not** to be used as a technical reference.

*XV-2 Film placed under/below tungsten eye shield at 3 mm depth (anterior surface of lens)

**TLD Microcubes placed under simulated eye lid using tungsten eye shields

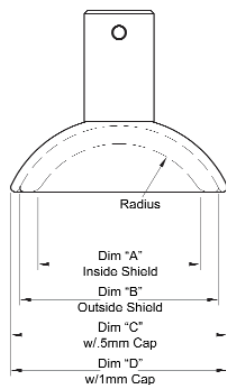

Item #	Size	Thickness	Radius	Dim A	Dim B	Dim C	Dim D
936-583	XS	2	6.5	11.6	15.7	17.3	18.3
936-585	S	2	7.5	13.3	17.4	18.7	20.0
936-587	M	2	8.5	15.0	19.1	20.6	21.7
936-589	L	2	9.5	16.7	20.8	22.7	23.2
936-591	XL	2	10.5	18.4	22.5	23.9	25.1
936-596	XS	3	6.5	11.0	17.4	18.9	19.9
936-598	S	3	7.5	12.7	19.1	20.8	21.7
936-601	M	3	8.5	14.4	20.8	22.7	23.5
936-623	L	3	9.5	16.1	22.5	23.9	25.1
936-627	XL	3	10.5	17.8	24.2	25.9	27.1

All Dimensions in Millimeters

Reference: Evaluation of Eye Shields made of Tungsten and Aluminum in High-Energy Electron Beam - Randi D. Weaver B.S. Fairview - University Med. Ctr. PO Box 494, 420 Delaware St. SE, Mpls., MN 55455 Int. J. Radiation Oncology Biol. Phys. Vol. 41 Nal, pp 233-237-1998

SHIELDING DEVICES & EYE APPLICATORS

CT / MR DUMMY EYE SHIELDS For Simulating a Tungsten Eye Shield

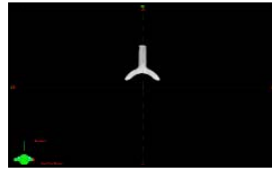

CT Image

The CT/MR Compatible Dummy Eye Shields for simulating the Tungsten Eye Shields are made of a non-metallic material and can be used in CT and MR.

Item	CT/MR Compatible Dummy Eye Shield
935-5831	Simulates a 936-583 with 0.5 mm Al Cap
935-5832	Simulates a 936-583 with 1.0 mm Al Cap
935-5851	Simulates a 936-585 with 0.5 mm Al Cap
935-5852	Simulates a 936-585 with 1.0 mm Al Cap
935-5871	Simulates a 936-587 with 0.5 mm Al Cap
935-5872	Simulates a 936-587 with 1.0 mm Al Cap
935-5891	Simulates a 936-589 with 0.5 mm Al Cap
935-5892	Simulates a 936-589 with 1.0 mm Al Cap
935-5911	Simulates a 936-591 with 0.5 mm Al Cap
935-5912	Simulates a 936-591 with 1.0 mm Al Cap

Item	CT/MR Compatible Dummy Eye Shield
935-5961	Simulates a 936-596 with 0.5 mm Al Cap
935-5962	Simulates a 936-596 with 1.0 mm Al Cap
935-5981	Simulates a 936-598 with 0.5 mm Al Cap
935-5982	Simulates a 936-598 with 1.0 mm Al Cap
935-6011	Simulates a 936-601 with 0.5 mm Al Cap
935-6012	Simulates a 936-601 with 1.0 mm Al Cap
935-6231	Simulates a 936-623 with 0.5 mm Al Cap
935-6232	Simulates a 936-623 with 1.0 mm Al Cap
935-6271	Simulates a 936-627 with 0.5 mm Al Cap
935-6272	Simulates a 936-627 with 1.0 mm Al Cap

SILVER-PLATED EYE SHIELDS FOR SUPERFICIAL 1/16" Thick With Handle



934-012

934-014

934-016



934-018



934-020

Eye Shields protect the patient's lens during radiation therapy treatments. They come in four different sizes and are highly polished.

The small and medium solid lead shields fit under the eyelid to protect the lens, while permitting irradiation to the entire thickness and width of the eyelids in the treatment of superficial basal cell carcinomas of the skin. Large solid lead shields are used when areas surrounding the eyes require irradiation, in which case, the shields are placed over the lid. When only a portion of the eyelid requires irradiation, an extra large shield with a window is properly placed over the eyelid.

Eye Shields are fabricated of virgin lead and are silver-plated for life long protection. Using a soft contact lens or coating the eye shield with dental wax will give a smooth surface on the eye to prevent scratching or irritation to the eye. The lead permits less than 1% transmission of the radiation intensity at 120 kVp (3 mm Al HVL).

Always consult the Radiation Physicist when using eye shields in electrons.

Please refer to Khan, F.M. Ph.D. (1976). Field Shaping in Electron Beam Therapy. *British Journal of Radiology*.

Specifications

Silver-Plated Lead Eye Shield

Density Lead: 11.35 g/cm³

Thickness: 1.7 mm

Warranty: One year

Storage Box for Eye Shields

Size: 7.75" W x 3.8" D x 2.4" H

Item	Silver-Plated Lead Eye Shield	Size
934-012	Small	2 x 2.3 cm
934-014	Medium	2.3 x 2.5 cm
934-016	Large	2.8 x 3 cm
934-018	Extra Large with Window	3.1 cm Dia.

Item	Optional Items
934-020	Storage Box for Eye Shields, 8 Compartments
933-122	Wax Sheets, 1 lb
937-700	Soft Contact Lenses, 6/Pkg

SHIELDING DEVICES & EYE APPLICATORS

LEAD AND TUNGSTEN EYE SHIELDS

External Shield - No Handle or Plating



The Lead and Tungsten Eye Shields have a smooth top. These Eye Shields do not include the aluminum caps.

Specifications

Lead Density: 11.35 g/cm³

Tungsten Density: 17 g/cm³

Item	Lead Eye Shield	Thickness
936-320	2.00 cm Diameter	5 mm
936-322	2.25 cm Diameter	5 mm
936-325	2.50 cm Diameter	5 mm
936-330	3.00 cm Diameter	5 mm
936-333	3.30 cm Diameter	5 mm
936-337	3.00 cm Diameter	6 mm
936-425	2.50 cm Diameter	7 mm
936-427	2.70 cm Diameter	7 mm
936-430	3.00 cm Diameter	7 mm
936-433	3.30 cm Diameter	7 mm
936-434	3.40 cm Diameter	7 mm

Item	Tungsten Eye Shield	Thickness
936-641	11.6 mm Diameter	2 mm
936-642	13.3 mm Diameter	2 mm
936-643	15.0 mm Diameter	2 mm
936-644	16.7 mm Diameter	2 mm
936-645	18.4 mm Diameter	2 mm
936-651	11.0 mm Diameter	3 mm
936-652	12.7 mm Diameter	3 mm
936-653	14.4 mm Diameter	3 mm
936-654	16.1 mm Diameter	3 mm
936-655	17.8 mm Diameter	3 mm

WARMING PLATE, STAINLESS STEEL CUP AND WAX SHEETS

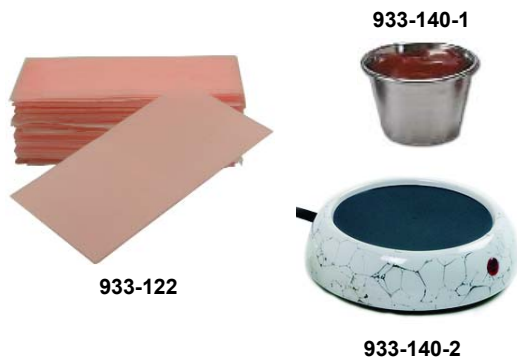

Specifications

Item 933-122 Wax Sheets

Size: 1.5 mm (0.15 cm) x 7.5 cm x 14.2 cm

Quantity: 35 sheets

Specific Gravity (H₂O = 1): 0.90

Weight: 1 lb (0.5 kg)

Item 933-140-1 Stainless Steel Cup

Capacity: 2.5 oz

Finish: Polished Stainless Steel

Item 933-140-2 Warming Plate

Heating Surface: 3.75" Diameter (9.5 cm) Non-Stick

On-Off Switch

Neon Light Indicator

Extra Long 60" (152 cm) Cord

Overall Size: 4" Diameter x 1.6" H (10.2 x 4.0 cm)

Color/Finish: White and Gray

Weight: 15 oz (0.43 kg)

Voltage: 120 V

Watts: 24 W

UL Approved

The Warming Plate and Stainless Steel Cup are used for melting wax to coat eye shields.

The wax is melted in a small stainless steel cup with a wide top on a small electric warming plate. When the wax is melted grip the eye shield with a forceps and dip into the wax for ten seconds and then remove. Constantly rotate it in all directions while the wax is cooling to prevent wax from building up in any one place. If the wax temperature is too low, it may go on the eye shield too thick and cause it to become bumpy. If the wax temperature is too high, it will not coat the eye shield evenly with a smooth surface layer.

Refer to "Wax Coatings", The Physics of Radiation Therapy by F.M. Khan, Ph.D., under 14.6 Field Shaping part D. Internal Shielding, last paragraph on page 340.

Item #	Description
933-122	Wax Sheets, 1 lb
933-140-1	Stainless Steel Cup, 2.5 oz
933-140-2	Warming Plate

SHIELDING DEVICES & EYE APPLICATORS

SOFT CONTACT LENSES

The Soft Contact Lenses are used to prevent scratches to the cornea when using eye shields.



Immediately remove the lens if the patient has any of the following problems

- Eye pain
- Eye stinging, burning, itching, excessive watering, dryness, etc
- Unusual eye secretions

Specifications

Size: 14 mm diameter

Center Thickness: 0.09 to 0.12 mm

Base Curve: Spherical surface flatter than the corneal curvature

Item #	Description
937-700	Soft Contact Lenses, 6/Pkg

CONTACT LENS CASE AND SOLUTION



Item 937-706 Contact Lens Cases

Not suitable for heat disinfection

937-711 Opti-Free Express Contact Lens Solution

- No-rub solution
- Cleans and disinfects
- Kills bacteria that can cause eye infections
- Removes protein daily
- Provides lasting moisture and comfort
- For use with both soft and silicone hydrogel contact lenses
- 4 oz (120mL)

Item #	Description
937-706	Contact Lens Cases, 4 Pairs/Pkg
937-711	Opti-Free Pure Moist Contact Lens Solution, 4 oz

STERILIZATION TRAY



Sterilization tray for Eye Shields. Consists of Base, Lid and Mat. Sterilizable by all standard methods of sterilization (autoclave, steam, dry heat, chemical).

Specifications

Size: 2.5" W x 6" L x 1.25" H (6.3 x 15.2 x 3.2 cm)

Item #	Description
936-500	Sterilization Tray

SHIELDING DEVICES & EYE APPLICATORS

CIDEX® OPA



Proven Efficacy

CIDEX® OPA Solution has been tested and cleared as a high-level disinfectant for use with the most widely used endoscopes.

- Designed for either manual or automatic reprocessing
- Manufactured to the highest standards for purity
- Effective against a wide array of microorganisms

Proven Safety

CIDEX® OPA Solution protects both patients and technicians, with a demonstrated safety profile that is backed by the heritage of Advanced Sterilization Products (ASP).*

- Safe to use for patients, healthcare professionals and instruments
- Low vapor pressure for minimal inhalation exposure risk
- No need for special ventilation
- Near-neutral pH level ensures compatibility with endoscopic instruments

Proven Value

CIDEX® OPA Solution is the number-one¹ product in high-level disinfection, offering more ways to make the most of your budget.

- Rapid disinfection improves productivity, allowing more endoscopes to be processed in less time²
- Noncorrosive formula protects your investment in instrumentation^{2,3}
- Long-lasting efficacy allows reprocessing of more devices per gallon than with glutaraldehyde²

*Please read and follow the Instructions For Use prior to using CIDEX® OPA Solution for important information, including contraindications, warnings and proper directions for use.

Rapid Action, Reliable Disinfection

Multiple studies have shown the efficacy of CIDEX® OPA Solution against bacteria, fungi, and viruses.^{4, 5} CIDEX® OPA Solution works within minutes and provides broad spectrum killing power—even in the presence of human serum.²

CIDEX® OPA Solution can be used straight from the bottle for extra efficiency.

- Requires no activation or mixing
- 5-minute soak time at 25°C in automatic endoscope reprocessors*
- 12-minute soak time at 20°C for manual reprocessing

Long Life, Lasting Power

A long shelf life and high reusability make CIDEX® OPA Solution a great value.

- 2-year unopened shelf life
- 75-day shelf life after opening the bottle

Using CIDEX® OPA Solution in an automatic reprocessor can mean 20% more cycles in a 14-day reuse cycle, compared with other solutions.⁵

- Sensitive test strips make it easy for you to test the minimum effective concentration (MEC) of ortho-phthalaldehyde, the active ingredient in CIDEX® OPA Solution

*When used or reused in a legally marketed automatic endoscope reprocessor that can be set to a minimum of 25° C.

Microbicidal Activity

The following table indicates the spectrum of activity as demonstrated by testing of CIDEX® OPA Solution using prescribed test methods.

Viruses Non-Enveloped		
Poliovirus Type 1	Rhinovirus Type 42	Adenovirus Type 2
Vaccinia (Wyeth)	Coxsackievirus Type B-3	
Viruses Enveloped		
Coronavirus HIV-1	Cytomegalovirus	Influenza Virus [Hong Kong]
	Herpes simplex Types 1,2	
Vegetative Organisms		
<i>Staphylococcus aureus</i>	<i>Salmonella choleraesuis</i>	<i>Pseudomonas aeruginosa</i>
	<i>Mycobacterium bovis</i>	
Fungi		
<i>Trichophyton mentagrophytes</i>		

Materials Compatibility

Metals		
Aluminum	Anodized aluminum	Brass
Carbon steel	Chrome-plated brass	Chrome-plated steel
Copper	Nickel-plated brass	Nickel-silver alloy
Stainless steel	Titanium	Tungsten carbide
Vanadium steel		
Plastics		
Acetal	Acrylonitrile-butadiene-styrene (ABS)	Nylon
Polyamide	Polycarbonate	Polyethylene
Polyethylene terephthalate (polyester)	Polymethylmethacrylate (acrylic)	Polypropylene
Polystyrene	Polysulfone	Polyvinylchloride (PVC)
PTFE		
Elastomers		
Kraton G	Natural rubber latex	Polychloroprene (Neoprene)
Polyurethane	Silicone rubber	
Adhesives		
Cyanoacrylate	EPO-TEK 301 epoxy	EPO-TEK 353 epoxy
Polyether Polysulfide		

Testing CIDEX® OPA Solution

To verify the efficacy of CIDEX® OPA Solution, ASP recommends testing for the minimum effective concentration (MEC) prior to each use. ASP offers test strips designed specifically for use with CIDEX® OPA Solution. Easy to use and read, CIDEX® OPA Test Strips are the most reliable means to verify that CIDEX® OPA Solution will effectively destroy microorganisms, including the highly resistant *Mycobacterium*.

References

1. 2008 Healthcare Products Information Services (HPIS) data, HLD Market Assessment. 2. Hession SM. Endoscope disinfection by ortho-phthalaldehyde in a clinical setting: an evaluation of processing time and costs compared with glutaraldehyde. Poster presented at: Society of Gastroenterology Nurses and Associates; May 18-23, 2001; Tampa, FL. 3. Vollmer C. New high-level disinfectant reduces equipment-repair costs. Infect Control Today, August 2002. 4. Akamatsu T, Minemoto M, Uyeda M. Evaluation of the antimicrobial activity and materials compatibility of orthophthalaldehyde as a high-level disinfectant. J Int Med Res. 2005;33:178-187. 5. Rutala WA, Weber DJ. New disinfection and sterilization methods. Emerg Infect Dis. 2001;7:348-353.

Item	Description
466-401	Cidex OPA, 1 gal
466-403	Cidex OPA Solution Test Strips, 60 strips/bottle

SHIELDING DEVICES & EYE APPLICATORS

EYE PLAQUES



971-XXX-01



971-XXX-05



971-XXX-10



971-XXX-15



971-XXX-20



971-XXX-25

The eye plaques are solid 18 kt. gold. Each eye plaque has 6 suture tabs. The eye plaques can be ordered with or without a notch for the optic nerve. The clear template metal ring is made of a high nickel alloy (78%).

Note: Silicone seed carrier must be ordered separately and is not returnable.

Specifications

18 Kt Gold Density: 15.58 g/cm³

Nickel Density: 8.912 g/cm³

Item	Description	Size
971-012-01	Gold Eye Plaque	12 mm
971-012-05	Gold Eye Plaque, Notched	12 mm
971-012-10	Clear Template Eye Plaque	12 mm
971-012-15	Clear Template Eye Plaque, Notched	12 mm
971-012-20	Silicone Seed Carrier	12 mm
971-012-25	Silicone Seed Carrier, Notched	12 mm
971-014-01	Gold Eye Plaque	14 mm
971-014-05	Gold Eye Plaque, Notched	14 mm
971-014-10	Clear Template Eye Plaque	14 mm
971-014-15	Clear Template Eye Plaque, Notched	14 mm
971-014-20	Silicone Seed Carrier	14 mm
971-014-25	Silicone Seed Carrier, Notched	14 mm
971-016-01	Gold Eye Plaque	16 mm
971-016-05	Gold Eye Plaque, Notched	16 mm
971-016-10	Clear Template Eye Plaque	16 mm
971-016-15	Clear Template Eye Plaque, Notched	16 mm
971-016-20	Silicone Seed Carrier	16 mm
971-016-25	Silicone Seed Carrier, Notched	16 mm
971-018-01	Gold Eye Plaque	18 mm
971-018-05	Gold Eye Plaque, Notched	18 mm
971-018-10	Clear Template Eye Plaque	18 mm
971-018-15	Clear Template Eye Plaque, Notched	18 mm
971-018-20	Silicone Seed Carrier	18 mm
971-018-25	Silicone Seed Carrier, Notched	18 mm
971-020-01	Gold Eye Plaque	20 mm
971-020-05	Gold Eye Plaque, Notched	20 mm
971-020-10	Clear Template Eye Plaque	20 mm
971-020-15	Clear Template Eye Plaque, Notched	20 mm
971-020-20	Silicone Seed Carrier	20 mm
971-020-25	Silicone Seed Carrier, Notched	20 mm

Also Available in 10 mm and 22 mm sizes

EYE PLAQUES LOADING STAND

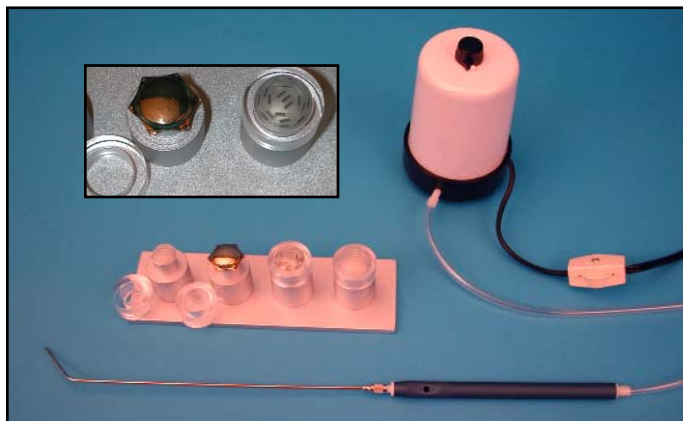

The Eye Plaque Loading Stand is designed to hold the Silicone Seed Carriers (971-xxx-20 or 971-xxx-25) for easier loading of the seeds into the Carriers and Eye Plaques. The Eye Plaque Loading Stand is comprised of an aluminum base with aluminum and acrylic holders. The aluminum base is 2" (5.08 cm) wide and 3/16" (0.188 cm) thick with the length dependant on the number of holders. The holders have a 1" diameter x 0.9" high (2.54 x 2.29 cm) aluminum base with a 0.5" (1.27 cm) high acrylic ring on top. The acrylic ring can be made for the following sizes of Seed Carriers: 10 mm, 12 mm, 14 mm, 16 mm, 18 mm, 20 mm and 22mm.

This item is custom made to the customer's specifications as to the size and number of holders needed on the stand. Customer must specify the size of holders needed, 10 mm, 12 mm, 14 mm, 16 mm, 18 mm, 20 mm and 22mm.

Item	Description
971-050	Eye Plaque Loading Stand

SHIELDING DEVICES & EYE APPLICATORS

TUNGSTEN EYE SHIELD FOR EYE PLAQUE



The Tungsten Eye Shield with 3 suture holes is placed on top of the eye plaque for shielding behind the eye.

Specifications

Tungsten Density: 17 g/cm³

Thickness: 1 mm

Radius: 10.2 mm

Diameter: 18.3 mm

Item	Description
971-110	Tungsten Eye Shield for Eye Plaque

SHIELDED EYE PLAQUE BOX

For Gas Sterilization



- Double box design prevents radiation leakage

The outer box of the Shielded Eye Plaque Box is made of stainless steel which has a handle, latch, and piano hinge. The top, bottom, and two sides are lined with 1/16" (0.16 cm) thick lead. The two ends are perforated stainless steel to allow the gas to flow through the box. The inside liner is perforated stainless steel and the two ends are lined with 1/16" (0.16 cm) thick lead. There are two compartments for the eye plaques, each compartment size is 1.25" x 1.25" x 7/8" deep (3.175 x 3.175 x 2.23 cm).

Item	Description
936-950	Shielded Eye Plaque Box for Gas Sterilization

PHOTON LEAD EYE/EAR SHIELD

With Tray Post



The Lead Eye/Ear Shield is an 8 cm lead cylinder attached to a 20 cm long stainless steel rod. The rod inserts into a hole in the swivel clamp which is connected to a 13 cm post that attaches to the treatment tray through a 1/4" (0.635 cm) diameter hole and is secured with a threaded knob.

Setting the lead cylinder shield for the proper divergence is accomplished by turning the collimator light on and adjusting the shield for a circular shadow on the patient. Two Eye Shields can be used on a tray for anterior eye shielding. A 13 cm or 30 cm extension (Item 588-002 or 588-003) can be added to the post to bring the shield closer to the patient.

The 13 cm Tray Post (Item 588-000) and the Lead Eye/Ear Shield (Item 588-007 to 588-020) must be ordered separately.

Item	Description
588-000	13 cm Tray Post with Swivel Clamp for Lead Eye/Ear Shield
588-002	13 cm Tray Post Extension
588-003	30 cm Tray Post Extension

Item	Lead Eye/Ear Shield
588-007	0.75 cm Diameter x 8 cm
588-010	1 cm Diameter x 8 cm
588-012	1.25 cm Diameter x 8 cm
588-015	1.5 cm Diameter x 8 cm
588-017	1.75 cm Diameter x 8 cm
588-020	2 cm Diameter x 8 cm

Custom Lead Eye/Ear Shields Available

J

SHIELDING DEVICES & EYE APPLICATORS

ADJUSTABLE TUNGSTEN EYE SHIELD FOR IRIS

Used For Electron Treatment

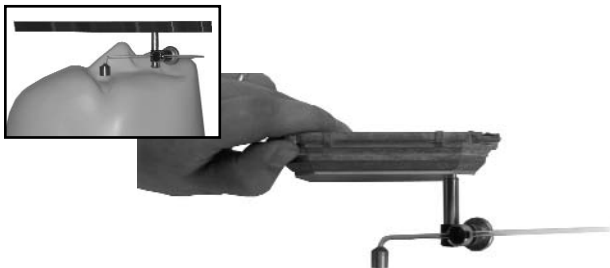

Adjustable Tungsten Eye Shield mounted to an electron cerrobend block as shown.

The eye shield is attached to a 5" (12.75 cm) long acrylic rod. Which connects to a clamp on the support rod. The support rod screws into the electron cerrobend mold.

The tungsten eyeshield sits approximately 5 mm above the eye. Instructed the patient to stare at the bottom of the eye shield, which can be marked with a dot. Dental wax can be used if build-up is needed.

This eyeshield is supplied with two support rods measuring 3.8 cm and 9 cm in length. These rods create the option to treat at an extended distance.

To use the Adjustable Tungsten Eye Shield it must be mounted to the electron cerrobend block by drilling a hole through the electron cerrobend block. Instructions and mounting tools are included with the Adjustable Tungsten Eye Shield.

Specifications

Material: Tungsten

Density: 17 g/cm³

Acrylic Density: 1.185 g/cm³

Size of Tungsten: 12 mm Dia x 10 mm Thick

Item	Description
936-925	Adjustable Tungsten Eye Shield for Iris

Custom Sizes Available Upon Request

TANGENTIAL BREAST CONE, BEST THERATRONICS THERATRON

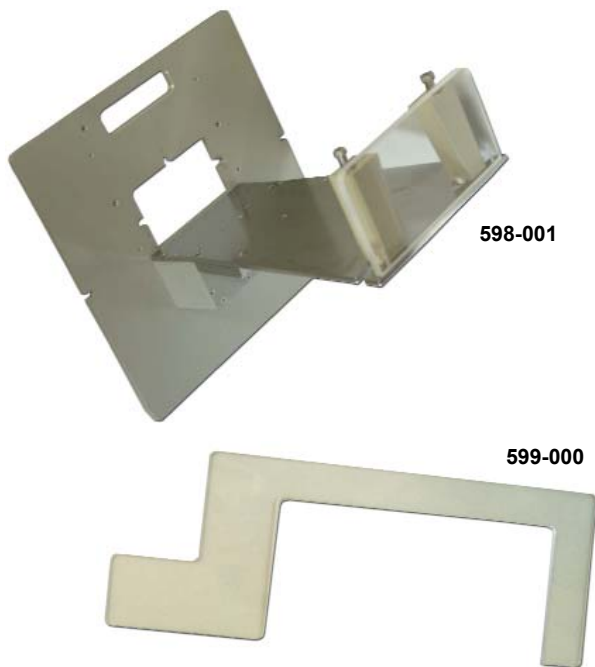

The Tangential Breast Cone for the Best Theratronics Theratron machines is a device designed to eliminate penumbra and beam divergence for the breast tangential portals. The device consists of a support plate and lead block for shielding of the contralateral side. An extension plate projects from the source head to the treatment distance. The extension plate is set to be off-center of the radiation source by one-half the diameter of the radiation source. This allows the entire radiation source to be utilized for treatment. Lateral adjustable lead trimming bars are provided to block the sides of the tangential fields, to insure that no overlapping with the supraclavicular field occurs. The end of the breast cone has an acrylic plate of 9.5mm thickness to provide equilibrium when treating the breast wall with Cobalt 60. The acrylic plate is removable for treatments without bolus.

The Back Pointer (Item 599-000) is a versatile device for accurately determining the exit points of the radiation beam when setting up a patient using the tangential breast cone. It is a light weight rigid device made of a Polycarbonate (lexan) material.

Specifications

Finishes: Tan textured polyurethane, Nickle plate, Clear anodized

Weight (without trimmers): 27.5 lb (12.5 kg)

Item	Description
598-001	Tangential Breast Cone, Theratronics Theratron-80cm
598-002	Tangential Breast Cone, Theratronics Theratron-100cm
599-000	Back Pointer for Tangential Breast Cone

SHIELDING DEVICES & EYE APPLICATORS

ROUND LEAD TESTICLE SHIELDS AND ADJUSTABLE TESTICLE SHIELD STAND



928-505 Adjustable Stand shown with Lead Testicle Shield

- 1/2" (1.27 cm) lead wall thickness
- An open sector is provided in each shield to allow comfortable positioning on the patient
- Lugs cast into each half of the shield unit provide anchor points for the two rubber straps used to hold the unit together
- All surfaces of the shields are coated with a tan polyurethane paint

The lead testicle shields are designed with a tongue and groove interlock to eliminate radiation leakage where the blocks are joined together and to prevent the halves from sliding apart. The shields top and bottom halves can be secured together with two rubber straps (supplied with each unit) or with nylon tape. Rotating the entrance of the shield toward the ceiling will reduce scatter radiation from entering the shield. A soft cotton sock or the Kianni cover (Item 928-150) can be used to cover the testicles when placing them inside a cold shield. The testicle shields are available in three sizes: small, medium and large. When using the Adjustable Stand with the shields, no rubber straps are needed.

This easily Adjustable Testicle Shield Stand will cradle all 3 sizes of the round lead testicle shields. A hand knob allows for easy vertical adjustment from 1" to 10" (five turns per inch). The counter weighted base is made of cast iron. A plastic plate, secured to the base, provides easy positioning. The unit can be used for anterior and posterior treatments.

It is recommended that the Adjustable Testicle Shield Stand (Item 928-505) be used while raising and lowering the testicle shields, as this will reduce patient discomfort.

Set-up:

1. Place half of shield in the stand cradle.
2. Adjust height and place testicles on the shield.
3. Fit the other half of the shield with the first half over the testicles and adjust height of stand if needed.
4. Rotate the opening of the shield toward the ceiling to reduce scatter from entering the shield.

The CT Testicle Shields are identical to the Lead Testicle Shields in size and shape but not weight. They are made of blue silicone rubber with shore hardness of 50A. The CT Testicle Shields do not use the rubber straps as the straps are too strong for the silicone rubber. The CT Testicle Shields should be used with the Adjustable Stand.

Reference: Testicular Doses in Definitive Radiation Therapy for Localized Prostate Cancer - C.J. Amies, M. App.Sc, H. Mameghan, F.R.A.C.R., A. Rose, M.A.I.P. and R. J. Fisher, Ph.D Radiation Oncology Biol. Phys, Vol. 32, No.3 pp. 839-846, 1995

Specifications

Item 928-200 (Small Lead Shield)

Size: 2" I.D. x 3" O.D. (5.09 x 7.65 cm)

Opening: 0.6" x 1.25" (1.53 x 3.19 cm)

Weight: 4 lb (1.8 kg)

Item 928-250 (Medium Lead Shield)

Size: 2.5" I.D. x 3.5" O.D. (6.37 x 8.92 cm)

Opening: 0.75" x 1.6" (1.91 x 4.08 cm)

Weight: 5.7 lb (2.6 kg)

Item 928-300 (Large Lead Shield)

Size: 3" I.D. x 4" O.D. (7.65 x 10.2 cm)

Opening: 1" x 2" (2.55 x 5.09 cm)

Weight: 7.25 lb (3.3 kg)

Item 928-505 (Stand for Lead Shields)

Size: 5" W x 10" D x 13.5" H (12.7 x 25.5 x 34.4 cm)

Weight: 10.6 lb (4.8 kg)

Item	Description
928-200	Lead Testicle Shield (Small) 2" I.D.
928-250	Lead Testicle Shield (Medium) 2 1/2" I.D.
928-300	Lead Testicle Shield (Large) 3" I.D.
928-500	Lead Testicle Shields, Set of 3 (Small, Med, Large)
928-505	Adjustable Stand For Round Lead Testicle Shields

J

SHIELDING DEVICES & EYE APPLICATORS

ROUND CT TESTICLE SHIELDS AND ADJUSTABLE CT TESTICLE SHIELD STAND



926-100 Adjustable CT Stand shown with CT Testicle Shield

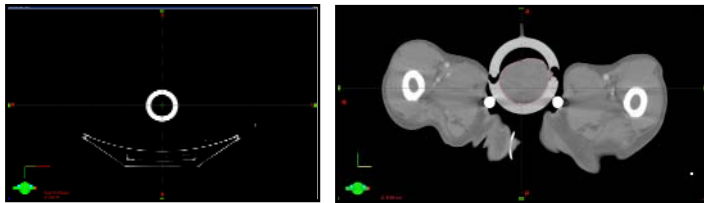

Image on CT Scans

- 1/2" (1.27 cm) silicone wall thickness
- An open sector is provided in each shield to allow comfortable positioning on the patient
- Lugs are molded into each half of the shield unit to simulate the Lead Testicle Shields
- All surfaces of the Adjustable CT Stand are coated with a tan polyurethane paint

The CT Testicle Shields are identical to the Lead Testicle Shields in size and shape but not weight. They are made of blue silicone rubber with shore hardness of 50A. The CT Testicle Shields do not use the rubber straps as the straps are too strong for the silicone rubber.

The CT testicle shields are available in three sizes: small, medium and large. A soft cotton sock or the Kianni cover (Item 928-150) can be used to cover the testicles when placing them inside a cold shield.

The CT Testicle Shields should be used with the Adjustable CT Stand. This easily Adjustable CT Testicle Shield Stand will cradle all 3 sizes of the round CT testicle shields. The holder for the testicle shield is made of PVC on this stand to minimize artifact on the CT scan. A hand knob allows for easy vertical adjustment from 1" to 10" (five turns per inch). The counter weighted base is made of cast iron. A plastic plate, secured to the base, provides easy positioning. The unit can be used for anterior and posterior treatments.

It is recommended that the Adjustable CT Stand for CT Testicle Shields (Item 926-100) be used while raising and lowering the testicle shields, as this will reduce patient discomfort.

Specifications

Item 926-200 (Small Silicone CT Shield)

Size: 2" I.D. x 3" O.D. (5.09 x 7.65 cm)

Opening: 0.6" x 1.25" (1.53 x 3.19 cm)

Item 926-250 (Medium Silicone CT Shield)

Size: 2.5" I.D. x 3.5" O.D. (6.37 x 8.92 cm)

Opening: 0.75" x 1.6" (1.91 x 4.08 cm)

Item 926-300 (Large Silicone CT Shield)

Size: 3" I.D. x 4" O.D. (7.65 x 10.2 cm)

Opening: 1" x 2" (2.55 x 5.09 cm)

Item 928-100 (Stand for Silicone CT Shields)

Size: 5" W x 10" D x 13.5" H (12.7 x 25.5 x 34.4 cm)

Weight: 10.25 lb (4.7 kg)

Item	Description
926-200	CT Testicle Shield, Silicone (Small) 2" I.D.
926-250	CT Testicle Shield, Silicone (Medium) 2-1/2" I.D.
926-300	CT Testicle Shield, Silicone (Large) 3" I.D.
926-100	Adjustable CT Stand For Round CT Testicle Shields

SHIELDING DEVICES & EYE APPLICATORS

THE KIANNI SCROTUM COVER

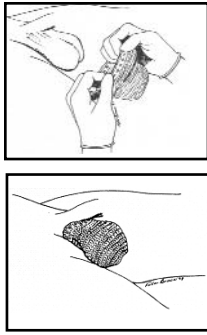

BENEFITS

- It covers the entire scrotum area, creating an insulated barrier between the scrotum skin and the cold metal shield. The warm feeling relaxes the testicles.
- It is made of an elastic netting (non-sterile) and threaded with an elastic drawstring. This elasticity allows expansion many times the actual dimensions of 3" x 3".
- It is sanitary, prevents the scrotum skin from coming in contact with the lead shields.

Individual plastic containers are included for patient identification.

Item	Description
928-150	The Kianni Scrotum Cover, 10/Pkg

TESTICLE RETRACTOR



The Testicle Retractor excludes a part or all of the testicle and scrotum from the direct beam while irradiating a portion of the scrotum.

This T-shaped device with a groove along the vertical support, allows a narrower blade (also with a groove) to be positioned in any vertical or angled orientation to the patient. It is fixed in position by a locking knob.

Item	Description
275-000	Testicle Retractor

WALL PLUGS



200-009



200-010



200-011

These wall plugs are designed to fit into the conduit used for cables running from the linac vault to the control area. The plugs provide a lead barrier in the wall conduit. The plugs have a channel for the cables so they can remain in the conduit permanently. The wall plug is made to the customer specified diameter and wall thickness.

Specifications

Item 200-009 Plug, Wall

Material: Lead and Stainless Steel

Lead Dimensions: 3" (7.62 cm) Thick x Customer Specified Diameter

Item 200-010 Plug, Outside Wall and 200-011 Plug, Inside Wall

Material: Lead, 5% Borated Polyethylene and Stainless Steel
Plug Dimensions: 1" (2.54 cm) Thick 5% Borated Polyethylene and 3" (7.62 cm) Thick Lead x Customer Specified Diameter

Item	Plug	Lead	5% Borated Polyethylene
200-009	Wall	3" (7.62 cm) T	
200-010	Outside Wall	3" (7.62 cm) T	1" (2.54 cm) T
200-011	Inside Wall	3" (7.62 cm) T	1" (2.54 cm) T

Items are Custom Made and Nonreturnable

SHIELDING DEVICES & EYE APPLICATORS

ANTERIOR AND POSTERIOR TREATMENT TABLE SHIELD

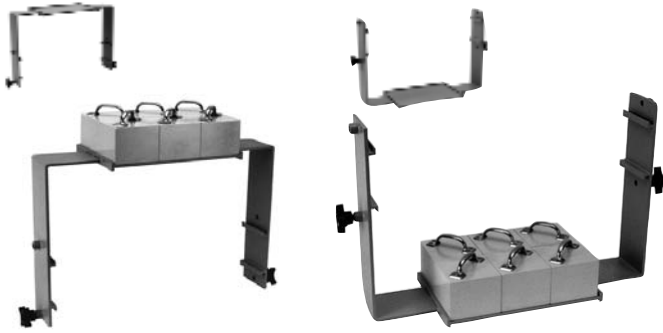

This unit attaches to the couch rails with two hand knobs. It can be used above or below the couch. Six lead blocks with handles are included. Each lead block weighs 21 pounds (9.5 kg) and is 8 cm thick x 10 cm square. A 1/4" (0.64 cm) high rail mounted around three sides prevents the lead blocks from sliding off. Anterior clearance to top of couch is 30 cm, posterior clearance is 20 cm. Each unit is custom made for the rail spacing. Please state the manufacturer and the model number of the couch when ordering.

Specifications

Shielded Area: 30 W x 20 L x 8 H cm

Item	Description
925-108	Anterior/Posterior Treatment Table Shield

J

ADJUSTABLE SHIELDING TABLE



Lead Filled Front Vertical Shield: 34.5" W x 8" H x 2" T
(87.9 x 20.4 x 5.09 cm)

Top Horizontal Tray: 36" W x 26" D x 2" T
(91.7 x 66.3 x 5.09 cm)

Lead Bricks with Handles within Tray: (20) 2" x 4" x 8"
(5.09 x 10.2 x 20.4 cm)

Lead Filled Side Vertical Shields Qty. 2: 28" W x 16" H x 2" T
(71.4 x 40.8 x 5.09 cm)

Opening Between Vertical Side Shields: 38" (96.86 cm)

Frame Construction Base: 2" (5.09 cm) square steel tubing

Overall Size: 47" W x 43" D x 77" H (119.8 x 109.6 x 196.3 cm)

Hand Crank Winches (2): Adjust the height of the top or side shields

Safety Lock Pins Included: 2

Casters: (4) 6" (15.3 cm) dia. swivel

Finish: Tan Textured Polyurethane

Weight: 1800 lb (817 kg)

Item	Description
925-020	Adjustable Shielding Table w/ Wheels

SHIELDING DEVICES & EYE APPLICATORS

“GRID” PHOTON BLOCK Special Fractionation Radiation (SFR)

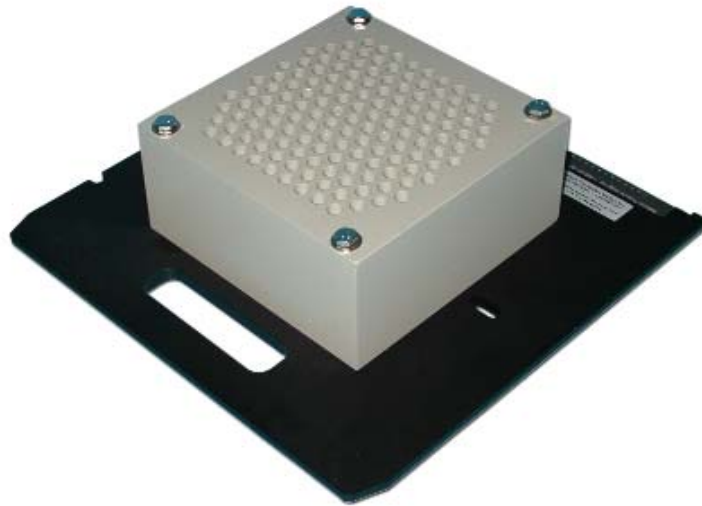

Special fractionation (GRID) is a new paradigm in radiation therapy for effective treatment of tumors that defy conventional dose/time fractionation.

The Special Fractionation Radiation (SFR) approach recreates a virtual brachytherapy dose distribution using megavoltage external beam radiation. This method combines the direct cellular response to high dose radiation with the indirect by-stander-effects of human tissue responses to produce enhanced biological effects. This treatment is particularly beneficial for the treatment of radioresistant or large tumors. The “GRID” Photon Block is used to treat these bulky tumors with SFR.

In the Department of Radiation Medicine at the University of Kentucky, over 200 patients having bulky malignant tumors in various sites, such as head and neck, lung and pelvis were treated. Excellent clinical results were obtained using the SFR technique. The efficacy and safety of using a large fraction of SFR are published in scientific journals¹.

The “GRID” Photon Block is made of a low melting alloy with the divergent holes spaced in a honeycomb fashion. At 100 cm each hole has a beam width of 14 mm and the distance from center to center of each hole is 21 mm.

¹High-Dose Spatially-Fractionated Radiation (GRID): A New Paradigm in the Management of Advanced Cancer by Mohammed Hoshiuddin, M.D., Mihoko Fujita, M.D., PH.D., William F. Regine, M.D., Ali S. Megouni, PH.D., Geoffrey S. Ibbott, PH.D., and Mansoor M. Ahmed, PH.D. - Department of Radiation Medicine, University of Kentucky, College of Medicine, Lexington, KY Int. J. Radiation Oncology Biol. Phys. Vol. 45, No. 3, pp 721-727. 1999

Weight: 48 lb (22 kg)

Item	“GRID” Photon Block
591-010	Varian Type III, 61.6 cm
591-011	Varian Type III 65.4 cm MLC
591-020	Siemens 56 cm - Screw Coding
591-021	Siemens 68.6 cm - Plug Coding
591-022	Siemens 56 cm - Plug Coding
591-030	Philips Elekta SL-20 65.4 cm

“GRID” Photon Blocks Can Be Manufactured for Any Accelerator

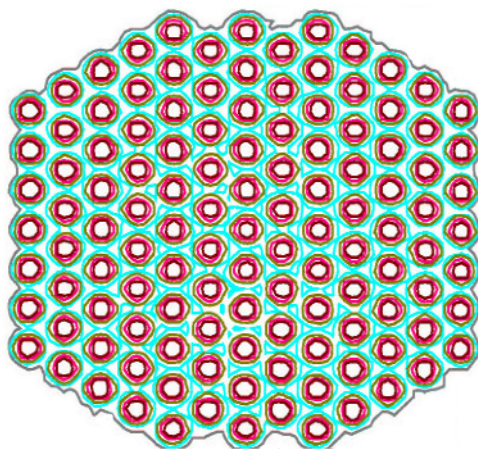

Isodose Lines

10% Gray
16% Cyan
30% Dark Green
70% Pink
90% Wine

25 x 25 Field Size

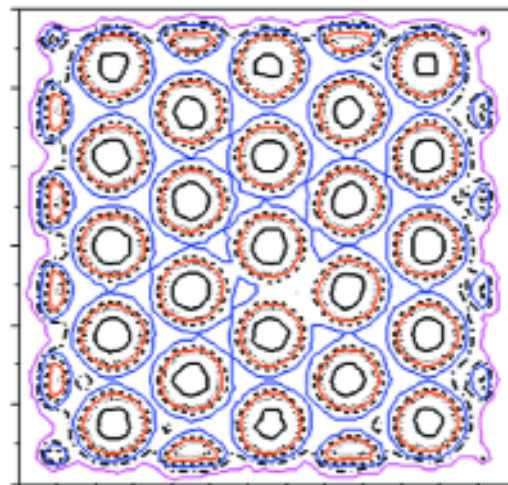

Isodose Lines

95 ———
70 ·····
50 ———
30 - - -
15 ———
10 - · -
5 ———

10 x 10 Field Size

SHIELDING DEVICES & EYE APPLICATORS

LEAD SHIELDING BLOCKS



NCRP Report No. 102 states the thickness of lead required reduce the beam to 5% is as follows:

4 MV - 6.4 cm	6 MV - 6.66 cm
10 MV - 7.31 cm	15 MV - 7.18 cm
20 MV - 7.05 cm	25 MV - 6.92 cm

Choose from three thicknesses: 5 cm (used with Cobalt 60 machines), 6 cm (used with 4 or 6 MV linear accelerators) and 8 cm (used with 6 MV accelerators and up). Blocks are made of gravity cast antimonial lead, resulting in harder blocks that resist scratching and corner breakage.

All surfaces are machined flat, square and smooth and are finished with a tough polyurethane paint. The bottom of each block is covered with thick vinyl to minimize scratching of the surface on which they are placed.

Blocks for use with a treatment tray can be studded with stainless steel bolts. The protruding stud of each block has a wing nut which secures the block to the treatment tray. This is necessary for rotational and angular treatments.

J We offer a large assortment of Lead Shielding Blocks for cobalt and linear accelerators. Custom sizes are also available.

All Lead Shielding Blocks on the following pages are made to order and are non-returnable.

STUDS FOR LEAD BLOCKS

Specifications

1/4" (6 mm) Blocking Tray: Needs 1/2" long stud

3/8" (9-10 mm) Blocking Tray: Needs 5/8" long stud

1/2" (13 mm) Blocking Tray: Needs 3/4" long stud



The studs are used to secure lead blocks to the treatment tray. The Heavy Duty T-Studs are recommended for lead blocks that are over 15 pounds. All lead blocks with a stud are sold with a wing nut for securing the block to the treatment tray. The area around the stud is packed with lead to prevent radiation leakage.

Item #	Description
500-150	Standard Stud Protrudes 1/2" x 10-32
500-152	Standard Stud Protrudes 5/8" x 10-32
500-154	Standard Stud Protrudes 3/4" x 10-32
500-156	Medium Duty Stud Protrudes 1/2" x 1/4-20
500-158	Medium Duty Stud Protrudes 5/8" x 1/4-20
500-160	Medium Duty Stud Protrudes 3/4" x 1/4-20
500-162	Heavy Duty "T" Stud Protrudes 1/2" x 1/4-20
500-164	Heavy Duty "T" Stud Protrudes 5/8" x 1/4-20
500-166	Heavy Duty "T" Stud Protrudes 3/4" x 1/4-20

KNOBS FOR LEAD BLOCKS



Item #	Description
565-050	1/2" Hex x 1 cm S.S. Thumb Nut 10-32 Thread - Pkg/12
565-075	3/4" Round x 1/2" S.S. Knob 10-32 Thread - Each
565-100	1" Round x 1/2" S.S. Knob 10-32 Thread - Each
565-140	1" Round x 1/2" S.S. Knob 1/4-20 Thread - Each

KNOBS WITH STUDS AND INSERTS



Item #	Description
565-203	1/2" Stud with Knob 1/4-20 Thread - Each
565-205	5/8" Stud with Knob 1/4-20 Thread - Each
565-207	3/4" Stud with Knob 1/4-20 Thread - Each
565-220	1/4-20 Threaded Brass Insert Installed in Lead Block - Each
565-223	8-32 Threaded Brass Insert Installed in Lead Block - Each

SHIELDING DEVICES & EYE APPLICATORS

LEAD SHIELDING BLOCK INFORMATION

Commonly Used Thicknesses

5 cm Thick - Cobalt 60
 6 cm Thick - 4 MV - 6 MV Linear Accelerators
 8 cm Thick - 10 MV & Higher Linear Accelerators

NCRP Report No. 102

Thickness of lead required to reduce beam to 5%

4 MV - 6.4 cm	6 MV - 6.66 cm
10 MV - 7.31 cm	15 MV - 7.18 cm
20 MV - 7.05 cm	25 MV - 6.92 cm

Please call or visit rpdinc.com for specific information on Lead Shielding Blocks

SQUARE BLOCKS

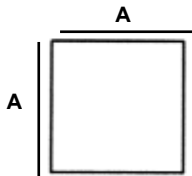

Item # Range	Description
510-015 thru 510-308	Square

DIVERGENT HOLE IN SQUARE BLOCKS

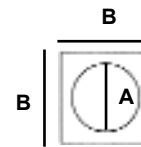

Item # Range	Description
535-055 thru 535-108	Divergent Hole in Square

RECTANGULAR/SPINAL CORD SHAPED BLOCKS

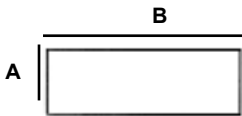

Item # Range	Description
511-025 thru 511-968	Rectangular/Spinal Cord

RECTANGULAR BLOCKS

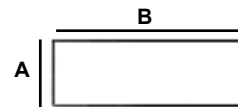

Item # Range	Description
512-025 thru 512-708	Rectangular

RECTANGULAR BLOCKS WITH CONCAVE SIDE

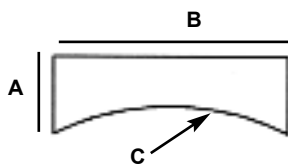

Item # Range	Description
525-155 thru 525-488	Rectangular with Concave Side

RECTANGULAR BLOCKS WITH CONVEX SIDE

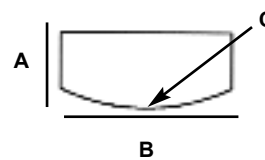

Item # Range	Description
524-125 thru 524-458	Rectangular with Convex Side

KIDNEY SHAPED BLOCKS

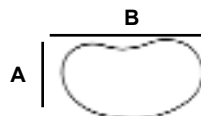

Item # Range	Description
526-135 thru 526-318	Kidney

J

SHIELDING DEVICES & EYE APPLICATORS

ROUND BLOCKS



Item # Range	Description
513-005 thru 513-408	Round

HALF ROUND BLOCKS

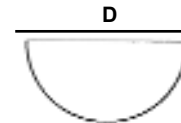

Item # Range	Description
514-085 thru 514-408	Half Round

TRIANGLE BLOCKS

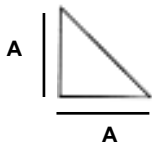

Item # Range	Description
515-025 thru 515-248	Triangle

POINTED RECTANGULAR BLOCKS

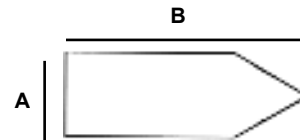

Item # Range	Description
519-115 thru 519-418	Pointed Rectangular

TRIANGLE BLOCKS

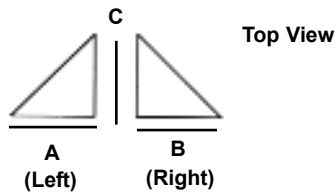

Item # Range	Description
516-115 thru 516-768	Triangle

ANGLED RECTANGULAR BLOCKS

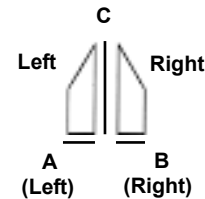

Item # Range	Description
518-105 thru 518-178	Angled Rectangular

ROUNDED RECTANGULAR BLOCKS

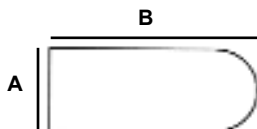

Item # Range	Description
520-105 thru 520-508	Rounded Rectangular

SALT CELLAR BLOCKS

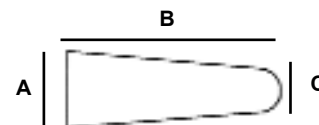

Item # Range	Description
521-115 thru 521-278	Salt Cellar

LARYNX BLOCKS

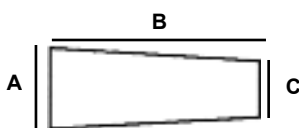

Item # Range	Description
523-135 thru 523-198	Larynx

TRAPEZOID BLOCKS

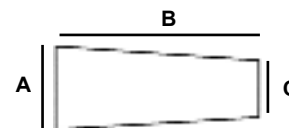

Item # Range	Description
522-125 thru 522-388	Trapezoid

SHIELDING DEVICES & EYE APPLICATORS

INTERLOCKING LEAD BRICKS

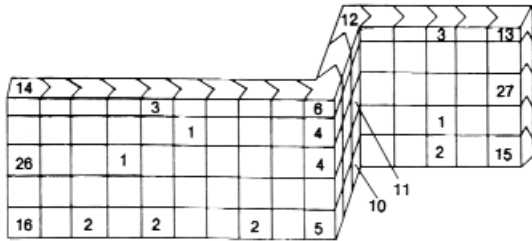
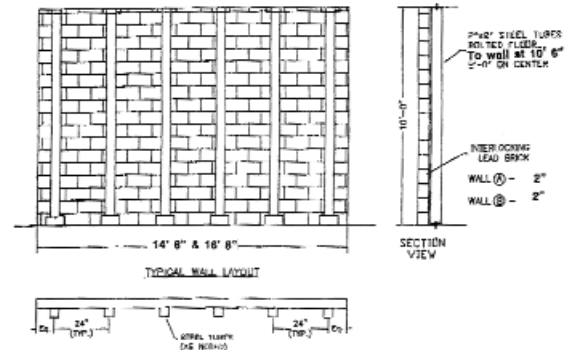
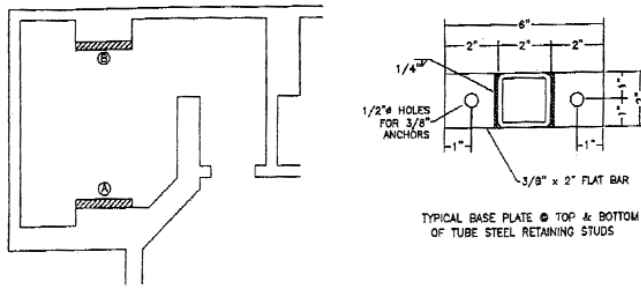
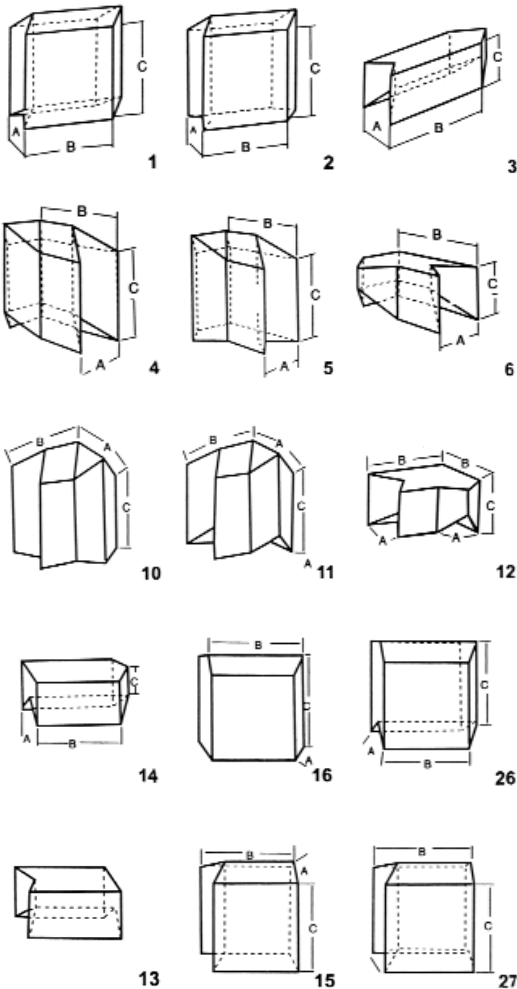

Diagram Shows Block Positions, Shape Function and Wall Alternatives

Interlocking lead bricks make it easy to erect, modify, and relocate protective walls and cells of any size. Interlocking V-shaped edges eliminate the danger of leakage common to straight-edged bricks. The interlocking design also creates a sturdier wall and minimizes the chances of toppling. The bricks have a durable paint finish to protect from direct lead contact.



Extra wall shielding can be accomplished using the 2" interlocking lead bricks. The customer must determine width, height, and thickness needed for extra shielding. Call for quote.



Item	Interlocking Lead Brick	Figure	AxBxC
001-100	Standard Wall, 13.2 lb (6 kg)	1	4x4x2"
001-200	Standard Base, 14.9 lb (6.77 kg)	2	4x4x2"
001-300	Standard Top, 5 lb (2.27 kg)	3	4x2x2"

Item	Interlocking Lead Brick	Figure	AxBxC
001-400	Corner for Wall, 13.2 lb (6 kg)	4	4x4x2"
001-500	Corner for Base, 14.9 lb (6.77 kg)	5	4x4x2"
001-600	Corner for Top, 5 lb (2.27 kg)	6	4x2x2"

Item	Interlocking Lead Brick	Figure	AxBxC
001-130	Reverse Corner for Base, 14.9 lb (6 kg)	10	4x4x2"
001-132	Reverse Corner for Wall, 13.2 lb (6.77 kg)	11	4x4x2"
001-135	Reverse Corner for Top, 5 lb (2.27 kg)	12	4x2x2"

Item	Interlocking Lead Brick	Figure	AxBxC
001-142	Left End Top, 5.2 lb (2.36 kg)	14	4x2x2"
001-147	Left End Base, 13.2 lb (6 kg)	16	4x4x2"
001-148	Left End, 14.9 lb (6.77 kg)	26	4x4x2"

Item	Interlocking Lead Brick	Figure	AxBxC
001-140	Right End Top, 5.2 lb (2.36 kg)	13	4x2x2"
001-145	Right End Base, 13.2 lb (6 kg)	15	4x4x2"
001-149	Right End, 14.9 lb (6.77 kg)	27	4x4x2"

SHIELDING DEVICES & EYE APPLICATORS

LEAD BRICKS



All ends are saw cut to fit together practically eliminating open spaces between stacked bricks. Bricks of various sizes, other than the standard, will be quoted upon request.

Item #	Size	Thickness	Weight
910-000	2" W x 6" L (5.08 x 15.24 cm)	4" (10.16 cm)	19.8 lb (9 kg)
912-000	2" W x 8" L (5.08 x 20.32 cm)	4" (10.16 cm)	26.4 lb (12 kg)

J

LEAD SHEET



Electron Shielding Thickness

$$\frac{\text{Energy}}{2} = \text{Lead Thickness in Millimeters}$$

These pure, cold-rolled Lead Sheets can be formed/cut into any shape to shield areas of concern. They will conform to irregularities. Common applications include electron and superficial shielding to protect against small amounts of radiation. The sheets are 99.90% pure lead. The thickness tolerance is $\pm 0.005"$ (0.0127 cm).

Unlimited scissors (RT-4932) will cut lead sheet thickness up to and including the 3.2mm thick lead sheet. The 6.3 mm thick lead sheet can be cut with a circular saw or jigsaw. Whenever cutting lead sheets be aware that cross contamination of lead particles may occur from the cutting tool. It is recommended to not use a cutting tool used on lead sheets to cut other non lead items.

Item #	Size	Thickness	Weight
3000-062	12" W x 24" L (30.48 x 60.96 cm)	0.063" (1.6 mm)	7.5 lb (3.4 kg)
3000-125	12" W x 24" L (30.48 x 60.96 cm)	0.125" (3.2 mm)	15 lb (6.8 kg)
3000-250	12" W x 24" L (30.48 x 60.96 cm)	0.25" (6.3 mm)	30 lb (13.6 kg)

FACE FORM FOR CONTOURING LEAD SHEETS



This solid cast iron face form can be used for contouring thicker lead sheets when needed. This face form will hold up to use of a hammer on the lead sheets.

There are four (4) rubber feet on the bottom to prevent the form from sliding.

Specifications

Size: 5.8" W x 8.8" L x 4.3" H (14.8 x 22.5 x 11.0 cm)

Weight: 28 lb (12.7 kg)

Item	Description
149-200	Face Form for Contouring Lead Sheets

SHIELDING DEVICES & EYE APPLICATORS

SNIPS



The Bulldog Aviation snips can be used to cut lead sheets up to 1/8" thick. This bulldog snip cuts straight and can be used in either hand. It has serrated blades.

Specifications

Nominal Length: 9" (22.9 cm)

Cut Length: 7/8" (2.22 cm)

Weight: 1 lb (0.5 kg)

Item	Description
878-738	Snips, Bulldog Aviation, 9" L



These Bulldog Blade Snips can be used to cut 1/4" thick lead sheets. This bulldog snip cuts straight and wide curves and can be used in either hand.

Specifications

Nominal Length: 16" (40.64 cm)

Cut Length: 2.5" (6.35 cm)

Weight: 3.5 lb (1.6 kg)

Item	Description
878-740	Snips, Bulldog Blade, 16" L

LEAD FOIL



Lead Foil can be cut easily with scissors and formed into almost any shape for shielding areas, partial areas or objects of all types.

Electron Shielding Thickness

$$\frac{\text{Energy}}{2} = \text{Lead Thickness in Millimeters}$$

Item #	Size	Thickness	Weight
3000-020	12" W x 4.5' L (30.5 cm x 1.37 m)	0.020" (0.5 mm)	5.25 lb (2.4 kg)
3000-030	14" W x 4.5' L (35.5 cm x 1.37 m)	0.030" (0.76 mm)	10 lb (4.5 kg)
3000-040	12" W x 4.5" L (30.5 cm x 1.37 m)	0.040" (1.016 mm)	10.5 lb (4.8 kg)

LEAD FOIL FOR TG-51



691-175



691-176



691-177

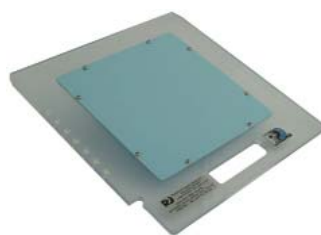

691-190

The lead foil thickness is 1 mm ±10% and 25 cm square. The lead is sandwiched between two 0.025" PVC sheets. The lead foil is also available mounted to a tray.

Item #	Description
691-175	Lead Foil for TG-51
691-176	Lead Foil, Varian III Wedge Slot Tray
691-177	Lead Foil, Varian II or III Block Tray
691-178	Lead Foil, Varian II Wedge Slot-Coding By-Pass
691-180	Lead Foil, Siemens Screw Coding, Block Tray
691-184	Lead Foil, Siemens, Block Tray w/ By-Pass Coding
691-185	Lead Foil, Siemens, Block Tray w/Coding Plug Pocket
691-190	Lead Foil, Elekta, Acrylic, Block Tray

SHIELDING DEVICES & EYE APPLICATORS

LEADED VINYL SHEETS



- Uniform density throughout
- Acid and alkali resistant
- Odorless
- Abrasion resistant

The Lead Vinyl Sheets are a flexible protective material available in a variety of lead equivalents for use wherever additional protection is required. It can be cut and shaped for many protective applications. It is 10% lighter in weight compared to that of lead rubber for the same lead equivalency. The sheets are sanitary and non-absorbing with smooth surfaces on both sides. They can be cleaned using a nonabrasive, household surface cleaner or WipeoutSM antimicrobial wipes. The material is non-aging, therefore, it has an indefinite shelf life.

Item #	Size	Thickness	Weight	Lead Equivalence	Color
3051-902	2' W x 3' L (61 x 91.4 cm)	0.063" (1.6 mm)	1.5 lb (0.7 kg) per sq. foot	0.0196" (0.50 mm)	Gray
3051-903	2' W x 3' L (61 x 91.4 cm)	0.125" (3.2 mm)	3.0 lb (1.4 kg) per sq. foot	0.0392" (1.0 mm)	Cream

LEADED ACRYLIC - CLEAR Pb® LEAD - PLASTIC SHEET

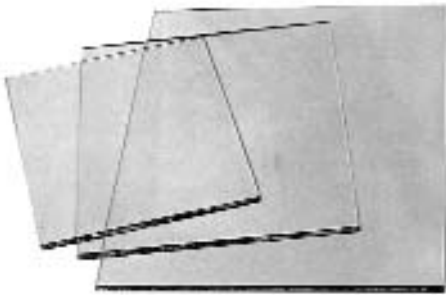

Leaded Acrylic Clear Pb® Lead Plastic x-ray shielding can be used for viewing windows and radiation shielding.

Leaded Acrylic Clear Pb® shatter-resistant lead plastic x-ray shielding is a lead impregnated transparent plastic sheet that contains 30% lead by weight. Its physical properties are similar to those of conventional acrylic resins and routine acrylic fabrication techniques (machining and cementing) can be applied.

Leaded Acrylic Clear Pb® meets ANSI Standards, Z97.1 and US Consumer Product Safety Commission standards.

Thickness	Lead Equivalency at 100 KV (Nominal)	Density (gm/cm ³)
12 mm	0.5 mm	1.6
18 mm	0.8 mm	1.6
22 mm	1.0 mm	1.6
35 mm	1.5 mm	1.6

Item	Description
3300	Leaded Acrylic- CLEAR Pb Lead-Plastic Sheet

Specify Size and Thickness When Ordering

LEAD GLASS (X-RAY PLATE GLASS)

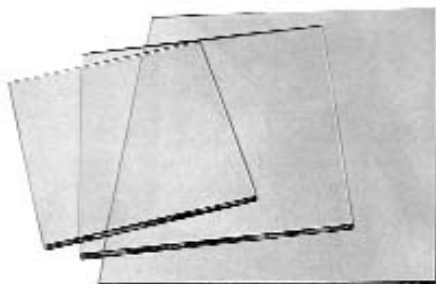

Thickness	Lead Equivalency at 100 KV (Nominal)	Density (gm/cm ³)
1/4" (0.64 cm)	2.0 mm	4.8
1/2" (1.27 cm)	3.7 mm	4.8
3/4" (1.91 cm)	5.7 mm	4.8
3/4" (1.91 cm)	7.7 mm	6.2
1" (2.55 cm)	10 mm	6.2

Item	Description
3500	Lead Glass (X-Ray Plate Glass)

Specify Size and Thickness When Ordering

SHIELDING DEVICES & EYE APPLICATORS

MATRIX THERMO-SHIELD™ Moldable Thermoplastic Radiation Shielding Material



MATRIX Material without Portal



MATRIX Material with Portal



MATRIX Material in 50 cc Syringe

The MATRIX patented shield is manually moldable thermoplastic material when heated in a water bath. MATRIX protects healthy tissues while allowing treatment to the exact treatment field during therapy. It may be quickly and repeatedly molded, adapted, shaped, stacked, or thinned directly on the patient at any time during therapy, thereby increasing treatment accuracy and decreasing clinical construction times.

Features:

- This material can be reshaped, readapted, thickened or thinned making it particularly adaptable for sensitive anatomy.
- Provides a time-saving factor as customized shields can be constructed in approximately 25 minutes.
- Provides a linear attenuation coefficient of approximately 34% of elemental lead.
- Eliminates fabrication of shields from plaster cast, cerrobend block or amorphous toxic leaded clay.
- Homogenous mix of hydrocarbon and bismuth particles provides uniform radiodensity.
- Material is non-toxic and biocompatible.
- Available as solid or with an "open" portal.
- Easily moldable to anatomic detail.
- Can be disinfected with glutaraldehyde spray (i.e. Cidex).
- Moldable at 108°- 132°F and becomes rigid at 102°F.
- Retains its shape and thickness for the course of treatment or can be modified if needed.

Usage:

The clinician chooses width, thickness, and either the solid or "open" portal shield, according to the determined therapy. The shield is then warmed in a water bath to 123° -128°F and molded to the healthy patient anatomy to protect it from electron or photon radiation during therapy. The shield sets at approximately 102°F and is removed from the patient. The shield is now rigid for accurate anatomic detail and can be placed repeatedly for multiple radiation sessions.

Specifications:

The only constituent used in the production of thermoplastic radiation shield is an FDA and ADA approved dental hydrocarbon impression compound for intro-oral usage and elemental bismuth-100 mesh, which is not absorbed through the skin. The thermoplastic dental compound and bismuth are blended in a volume ratio of approximately 66:33. The manufacturing process bonds the dental compound to the bismuth to produce the dense thermoplastic radiation shield.

Specifications:

Dimensions:

Slabs: 8 x 8 cm or 12 x 12 cm
Thickness: 13 or 16 mm
Portal diameter: 2.5 cm
Syringes: 50 cc

Color: Brown

Odor: Chocolate

Density: Approximately 4.2 gm/cc

Environmental Factors:

MATRIX will maintain proper performance with normal use under the least favorable of the following conditions:

- Ambient temperature range of 59°F to 95°F
- Relative humidity range of 30% to 75%, including condensation
- Atmospheric pressure range of 700 hpa to 1100 hpa

MATRIX will not be adversely affected for up to 15 weeks while packed for transport or storage or if exposed to:

- Ambient temperature range of -40°F to 234°F
- Relative humidity range of 10% to 100%, including condensation
- Atmospheric pressure range of 500 hpa to 1060 hpa

Single patient use.

Not Sterilized.

Reimbursement is for a complex shield-CPT 77334.

The syringe of Hydrocarbon only (thermoplastic without bismuth; specific gravity of 1.66) can be used to fabricate a backscatter electron shield on a MATRIX shield.

Item #	Description
MX1-0813	Matrix Thermo-Shield™ 8 x 8 cm x 13 mm
MX1-0813P	Matrix Thermo-Shield™ 8 x 8 cm x 13 mm with Portal
MX1-0816	Matrix Thermo-Shield™ 8 x 8 cm x 16 mm
MX1-0816P	Matrix Thermo-Shield™ 8 x 8 cm x 16 mm with Portal
MX1-1213	Matrix Thermo-Shield™ 12 x 12 cm x 13 mm
MX1-1213P	Matrix Thermo-Shield™ 12 x 12 cm x 13 mm with Portal
MX1-1216	Matrix Thermo-Shield™ 12 x 12 cm x 16 mm
MX1-1216P	Matrix Thermo-Shield™ 12 x 12 cm x 16 mm with Portal
MX1-500	Matrix Thermo-Shield™ 50cc Syringe
MX2-500	Matrix Thermo-Shield™ Hydrocarbon ONLY 50cc Syringe
MX1-300	Matrix Thermo-Shield™ Parchment Paper

SHIELDING DEVICES & EYE APPLICATORS

Relative Value at the depth of maximum dose in Solid Water® vs. thickness of MATRIX Thermo-shield

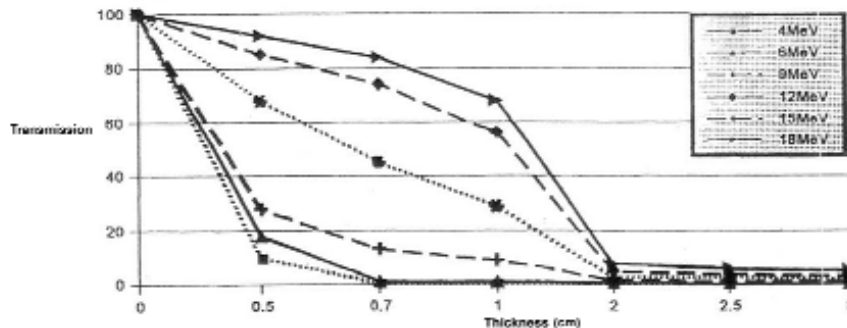

* This data is for reference only and should not be used for clinical purposes.

Attenuation characteristics of a new compensator material: Thermo-Shield for high energy electron and photon beams

Bhudatt R. Paliwal,^{a)} Stephen Rommelfanger, and Rupak K. Das
 Med. Phys. 25 (4), April 1998 pp.484-487

TABLE I. Measurements of electron transmission (percentage) at depth of maximum dose through increasing thickness of Thermo-Shield. For each beam energy, the data are normalized to its corresponding value measured for 0 cm thickness.

Thickness (cm)	Electron beam energy					
	4 MeV	6 MeV	9 MeV	12 MeV	15 MeV	18 MeV
0.00	100.0	100.0	100.0	100.0	100.0	100.0
0.50	10.0	18.0	28.0	68.0	85.0	92.0
0.70	0.4	1.2	13.3	45.0	74.0	83.9
1.00	0.4	0.9	9.0	29.0	56.0	68.0
2.00	0.3	0.6	1.4	2.8	4.9	7.6
2.50	0.2	0.4	1.1	2.5	4.0	6.1
3.00	0.2	0.3	1.0	2.0	3.2	5.2

The authors conclude that thermoshield is a desirable material for use in clinical radiation therapy as a compensator or shielding material for photon beams. For electrons Thermoshield acts as a good shielding material. The authors describe a new highly attenuating thermoplastic with extremely desirable physical and radiation shielding properties.

Comparison of linear attenuation coefficient of Thermo-Shield with other materials relevant to radiotherapy

